

Technical data

S.CF 24 G – 45' EURO LIGHT

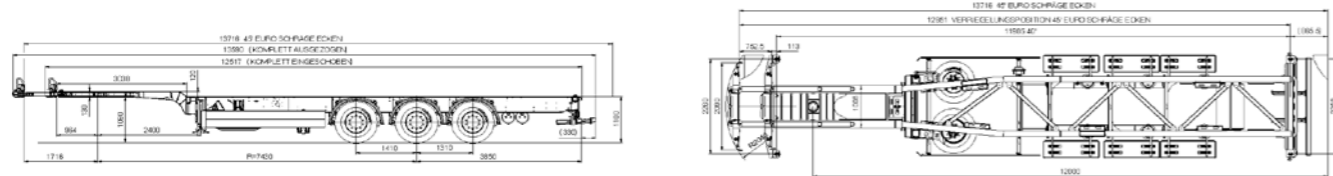

Permissible / technical axle load	24,000 kg	27,000 kg
Permissible / technical trailer load	11,000 kg	12,000 kg
Permissible / technical total weight	35,000 kg	39,000 kg
Unladen weight basic configuration		4,250 kg
Fifth-wheel height, unladen		1,100 mm
Fifth-wheel height, laden		1,075 mm
Low bed loading height, unladen		1,100 mm
Low bed loading height, laden		1,075 mm
Crank height		120 mm
Body height at front frame neck incl. pick-up plate (neck height)		130 mm
Front beam		1,695 mm
Wheelbase		7,430 mm
Front axle spacing		1,410 mm
Rear axle spacing		1,310 mm
40' with tunnel		Standard
45' EU-container with long tunnel and sloping edges *		Standard

* No certificate of exemption as per § 70 Road Traffic Act required. We reserve the right to make technical changes.

One-Stop Solution

Premium Services from Schmitz Cargobull



SCHMITZ
CARGOBULL

The Trailer Company.



Containerchassis S.CF 45' EURO LIGHT

More Payload for Your Transport with 40' and 45' Containers

Benefits at a glance:

- **Robust:** payload- and weight-optimised, diagonally braced frame
- **Efficient:** easy operation, low maintenance, maximum uptime
- **With certificate of exemption:** the S.CF 45' EURO LIGHT also carries 45' containers with a short tunnel or straight edges

S.CF-EURO LIGHT-DE2GB-1073-4120 We reserve the right to make changes. Some illustrations show special equipment.

Container Chassis S.CF 45' EURO LIGHT

The Effective Light Transporter: Light Chassis with Diagonal Bracing

The S.CF 45' EURO LIGHT with standard equipment is equipped to transport 40' tunnel containers and 45' EU containers.

With a low unladen weight, you benefit from additional payload, lower fuel consumption and an outstanding price/performance ratio with our Light chassis.

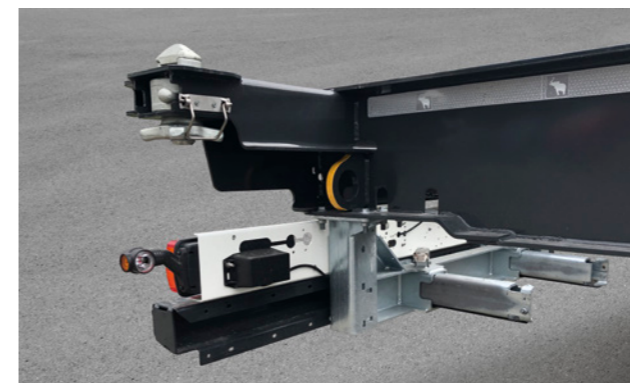
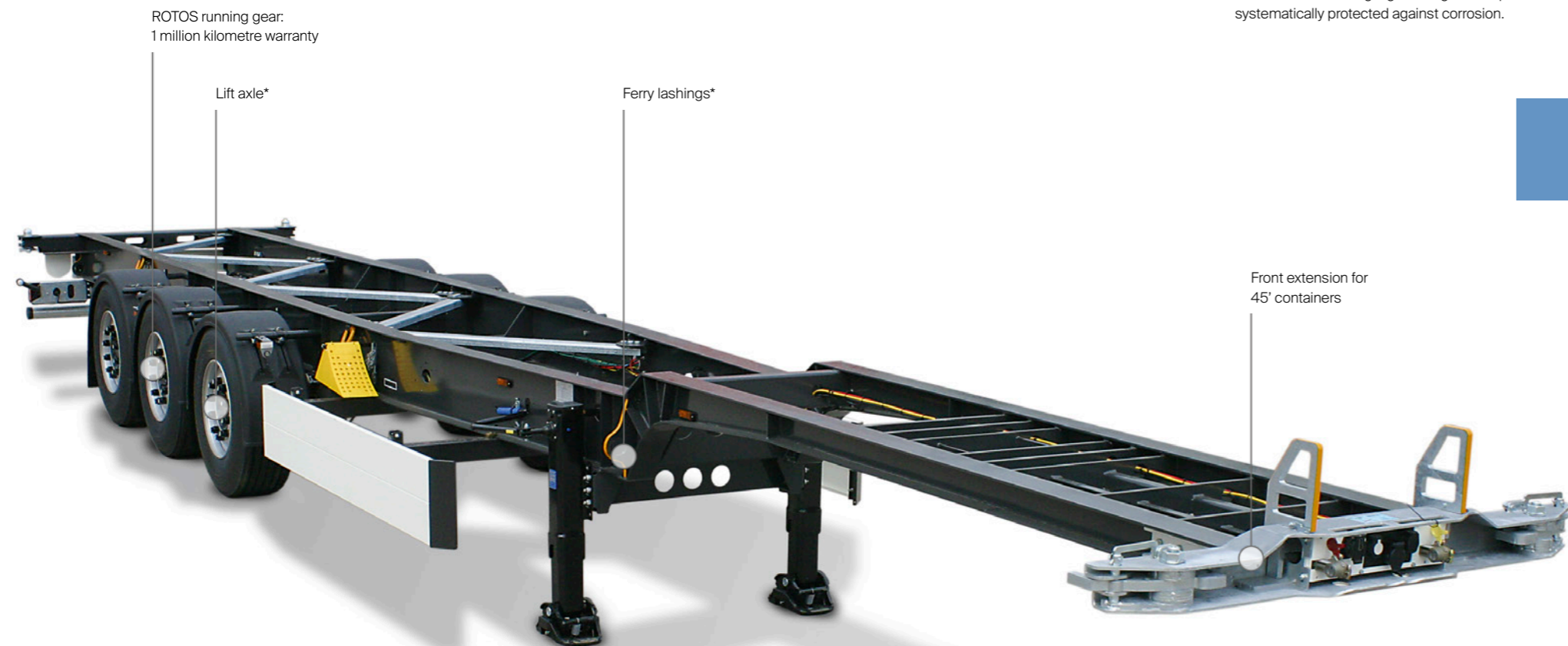

Long service life: Schmitz Cargobull container chassis are constructed using high-strength steel profiles and systematically protected against corrosion.



The **front extension** for 45' containers is spring-mounted on roller bearings, providing simple, safe and rapid handling.

Container layout

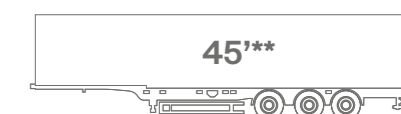
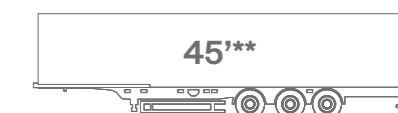
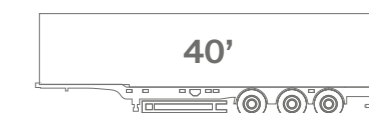

*** Certificate of exemption as per § 70 Road Traffic Act required.



Standard **TWIST LOCK** locking mechanism: lowerable and with anti-twist device.

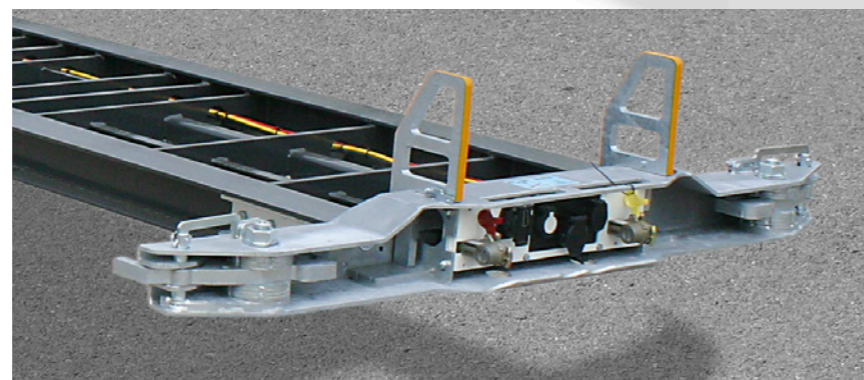

For carrying 45' EU containers: the patented **MULTI LOCK®** locking mechanism on the mechanical front extension for total versatility.



The **lift axle*** as a starting aid extends the wheelbase and, thus, increases the pressure on the drive axle.

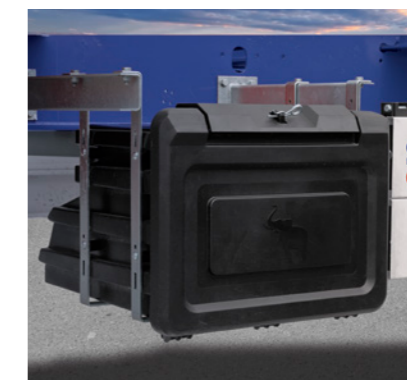

The **sturdy toolbox*** safely and cleanly stores all necessary equipment.



The container trailer chassis can be equipped with **ferry lashings*** for use with ferry transport.