



**M.KI Tipper Trucks
Z.KI Central Axle Tipper Trailers
The Product Range.**

Trailer

Services

Technologie

just more.

The Rear Tipper for Motorised Vehicles. High Performance Off-Road.

The Motorised Vehicles	3
The Tipper Body	5
The Pendulum Tailgates and Bodies	7
Sophisticated Details	9
The Load Securing System	11
The Program Overview	12
Technical Specifications	18
Contact	21

We build your tipper trucks using construction vehicles from all major manufacturers. The rounded bodies are made of high-strength HB 450 steel and mounted on the motor vehicle chassis with extremely torsion-resistant subframes in accordance with the manufacturer's specifications. Naturally, we also offer you this solution as an assembly kit for your existing vehicles. Talk to us about it!



The Motorised Vehicles. Tipper Bodies for All Major Brands.

You select the motor vehicle and we mount your optimal tipper truck on any current three and four axle construction vehicle from the leading manufacturers. You can choose from between rounded steel bodies and steel box bodies with external reinforcing ribs and body volumes between 13.8 m³ and 19.1 m³, depending on the length of the vehicle and the application. We can also provide you with the high-quality Schmitz Cargobull tipper truck body as a precisely customised assembly set for your existing vehicles - Including the exterior paintwork on the body in your company colours.

Optimally designed Schmitz Cargobull tipper bodies are available for motor vehicles from these brands:

- DAF
- IVECO
- MAN
- Mercedes-Benz
- Renault Trucks
- Scania
- Volvo





We build steel box bodies to meet your project business requirements: Designed specifically for the operating conditions and bulk goods.

M.KI tipper truck – The advantages at a glance:

- ✓ Tipper bodies for motor vehicles from all leading brands
- ✓ Available for three and four axle chassis
- ✓ The highest quality series production to your customised specifications
- ✓ Bodies in four lengths and two side wall heights

Body length	4.5 m	5.0 m	5.5 m	5.8 m
Wall height (volume)	1,360 mm (13.8 m ³)	1,360 mm (15.3 m ³)	1,360 mm (16.8 m ³)	1,360 mm (17.7 m ³)
	1,460 mm (14.8 m ³)	1,460 mm (16.5 m ³)	1,460 mm (18.1 m ³)	1,460 mm (19.1 m ³)
Wheel layout				
6 X 4	✓	✓		
6 X 6	✓	✓		
8 X 4			✓	
8 X 6			✓	
8 X 8				

The Tipper Body. The Perfect Unit with Your Base Vehicle.



The subframe is mounted on the vehicle chassis according to the vehicle manufacturer's assembly guidelines.

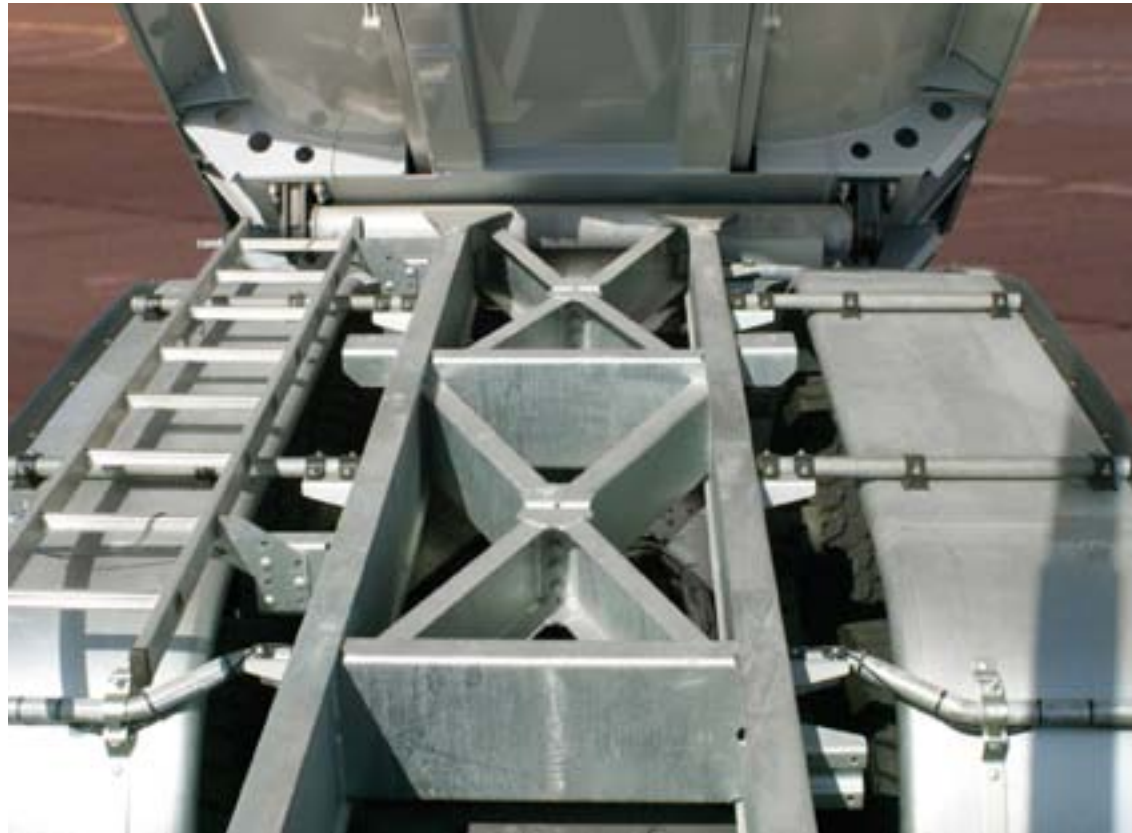

The extremely torsion-resistant dual diagonal-cross subframe transforms the vehicle and the body into a single extremely durable, safe and efficient unit.



On the way to the vehicle assembler: Tipper body as an assembly-ready kit.



For maximum safety when tipping: Torsion-resistant subframe and body design.

Pendulum Tailgates and Bodies for Every Application.



The external pendulum tailgate simplifies partial unloading and is optionally available with a top-mounted pendulum bearing.



The recessed pendulum tailgate with chute enables controlled unloading close to the road paver and prevents the load from sliding beneath the vehicle towards running gear.



Maximum opening angle: The hydraulic cylinder for operating the recessed pendulum tailgate...



... and is integrated into the upper lip to protect it.



Steel box body with recessed pendulum tailgate and chute.



The body position guide serves to guide the body into the right position while lowering the body when the vehicle is inclined sideways.



The mechanical locking hooks on the pendulum tailgate lock automatically.



The durable draw hooks on the tailgate are guided by a robust rods.



The tipping bearings on the body of a long service life and require little maintenance.



The bearings on the lifting hydraulics have a low-wear and torsion-resistant design.

Sophisticated Details.



The protective plate on the front upper lip prevents damage caused by overflowing bulk goods.



Side fender plates on the rounded steel body protect the running gear when loading.



The robust underride guard is weight-optimised and folds up easily.



Underride guard folded up for unloading close to the road paver.



The sensible option: The light-weight aluminium ladder is mounted above the mudguard using two clips.



The bracket for the integrated mudguard is mounted directly onto the subframe. The optional rear light protective gratings are made of corrosion-resistant steel.



Easily accessible spare wheel carrier



The maintenance-friendly hydraulics tank is integrated securely into the body.

The Tipper Tarpaulins.



The rollup tarpaulin covers the body flush with the lip and secures the load against the influence of the wind.



Removable tarpaulin with zig-zag anchoring.



Functional solution: Body with rollup tarpaulin.



Side ladder for load inspection.

The Program Overview.

Steel Rear Tipper Body for M.KI Motor Vehicles.



Financing



24 h spare parts



24 h Euroservice



Service partners



Pendulum bearing



Raised



Double-hinged

Pendulum tailgates



Hydraulic tailgate

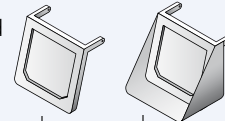

Tarpaulin



Rollup tarpaulin



Hydraulic tank



Aluminium ladder



Fire extinguisher



Toolbox



Water tank



Spotlight

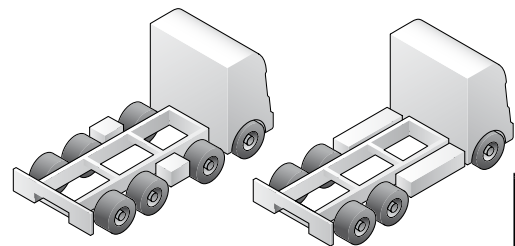
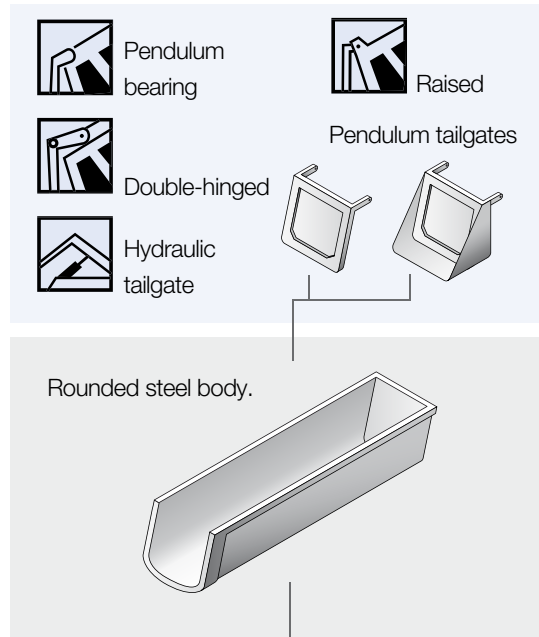

4-axle motor vehicle

3-axle motor vehicle



UFS folding

The Three-Side Central Axle Tipper Trailer. Your Flexible Additional Capacity.

- The Three-Side Tipper Body 14
- The Chassis and Accessories 16
- The Program Overview 17

The Z.KI central axle tipper trailers bring a flexible addition to your fleet for transporting bulk goods, packaged goods, pallet goods and technical equipment. The three-side tipper trailers provide additional loading capacity when you need.



The Three-Side Tipper Body.

With 10.3 m³ loading volume and without middle, the three-side tipper body of the Z.KI central axle tipper trailer not only provides you with a large capacity but also with a maximum of flexibility when loading and unloading: The single-piece side-walls and the tailgate are pendulum mounted, can be folded down and are available in weight-saving aluminium or wear-resistant steel.



The steep tipping bridge can be tipped to three sides using hydraulics. The bottom plate consists of wear-resistant HB 450 steel.



The screwed corner stanchions are made of galvanized fine-grain steel and can be easily adjusted using an eccentric cam.



The single-piece steel sidewall is a robust tank membrane construction.



Central axle tipper trailer with aluminium-side walls for optimized payload.



The central lock for the pendulum-mounted side walls on the front bulkhead possesses an over-centre helper spring for rapid, safe locking.



The aluminium side walls can be opened and closed conveniently with the side wall raising aid on both sides.



Without middle stanchions: The folded down bulkhead provides optimal access to the tipping bridge.



The rear wall with the top-mounted pendulum bearing creates a large opening cross-section.

Z.KI central axle tipper trailer – The advantages at a glance:

- ✓ Three tipping directions for universal range of applications
- ✓ Aluminium or steel side walls
- ✓ Extremely good manoeuvrability due to the central axle

The Chassis and Accessories.



The divided rollup tarpaulin with the attached rear tarpaulin section for legally required load securing. The roof design is stabilised by a longitudinal member.



The odometer provides you with a reliable overview of the mileage.



The underride guard can be folded up in order to unload close to the road paver.



The hot galvanized, welded steel frame ensures a long service life.



The axle unit with air suspension and EBS is available with either disc brakes or drum brakes.

The Program Overview.

Z.KI Central Axle Three-Side Tippers



Financing



24 h Euroservice



Full Service



24 h spare parts



Service partners



Tyre service



Odometer



Fire extinguisher



Aluminium wheel rims



Stabilisers



Pendulum bearing



Top-mounted

Pendulum tailgates

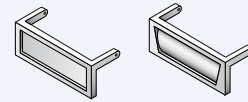

Tarpaulin



Rollup tarpaulin
Roof frame

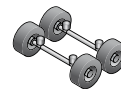
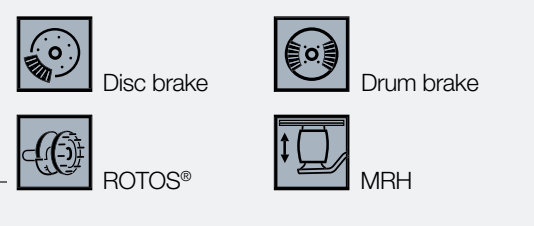
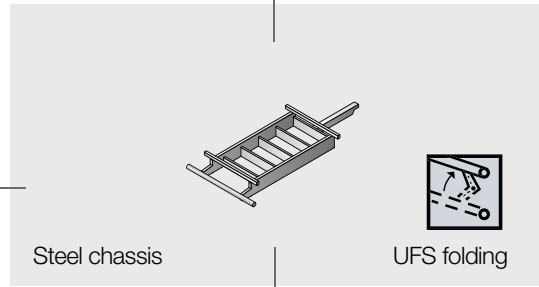
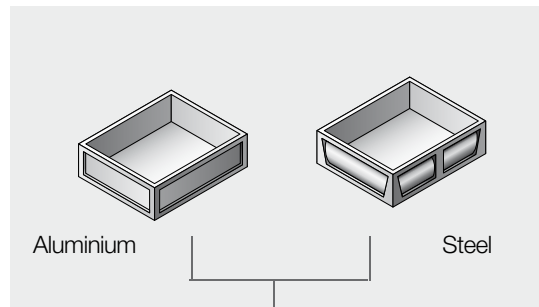

Technical Specifications At a Glance

Tipper Trucks	19
Central Axle Tipper Trailers	20



Technical Specifications

M.KI Tipper Truck

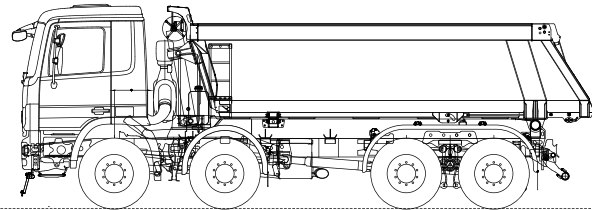

Rear wall version

Height	Floor	Bulkhead	Side	Rear wall	Pendulum tailgate/chute				Exterior pendulum tailgate				
					4.5	5.0	5.5	5.8	4.5	5.0	5.5	5.8	
1,360 mm	6 mm	5 mm	5 mm	5 mm	●	●	●	●	●	●	●	●	●
	8 mm	5 mm	5 mm	5 mm			●	●			●	●	
1,460 mm	6 mm	5 mm	5 mm	5 mm	●	●	●	●	●	●	●	●	●
	8 mm	5 mm	5 mm	5 mm			●	●			●	●	

Height	Floor	Bulkhead	Side	Rear wall	Hydraulic tailgate/chute				Hydraulic exterior tailgate				
					4.5	5.0	5.5	5.8	4.5	5.0	5.5	5.8	
1,360 mm	6 mm	5 mm	5 mm	5 mm									
	8 mm	5 mm	5 mm	5 mm			●	●			●	●	
1,460 mm	6 mm	5 mm	5 mm	5 mm									
	8 mm	5 mm	5 mm	5 mm			●	●			●	●	

● = Available
 ● = Assembly time two weeks after delivery of a standard chassis

Technical Specifications

Z.KI Central Axle Tipper Trailer

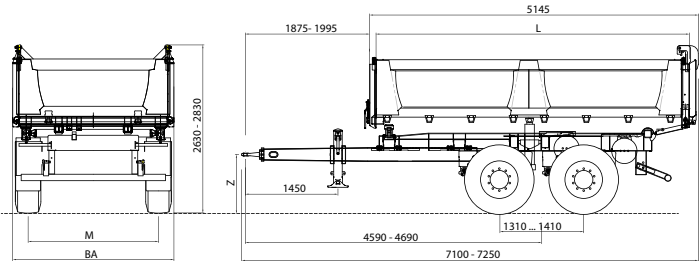

Tyres	385/65 R 22.5 (4 x)
Technical axle load	2 x 9,000 kg
Total weight	18,000 kg
Empty weight (aluminium side walls)	approx. 4,500 kg
Payload	approx. 13,400 kg
Supported load	1,000 kg
Spring track	1,300 mm
Track width (M)	2,040 mm
Overall length (LA)	7,055 mm
Overall width (BA)	2,530 mm
Drawbar height, loaded (Z)	840 - 960 mm
Free drawbar length	1,925 + 3 x 50/- 1 x 50 mm
Internal loading surface height	2,326 mm
Internal loading surface length (L)	4,900 mm
Dropside height	900 mm
Rear wall height	900 mm
Side tipping angle	48°
Rear tipping angle	50°
Loading volume	10,2 m ³

All dimensions and weights are approximate. The data relate to a vehicle with base fittings without taking into consideration possible additional fittings. Issued: august 2010

Our Sales Divisions in Europe

Addresses Germany	22
Addresses Europe	23

Always good advice: Our sales staff speak your language. At Schmitz Cargobull you have direct contact partners throughout Europe, who are immediately available to respond to your questions and take care of your needs.



Our Sales Divisions in Europe

Schmitz Cargobull Sales are there for you - Throughout Europe. Call us when you have questions about new vehicles, used vehicles, financing, maintenance, insurance, spare parts supply and any other questions you may have about your trailer. Our specialists will listen to you, provide you with detailed information and work together with you to develop the customised solution for your company.

D Schmitz Cargobull AG
Bahnhofstraße 22
D-48612 Horstmar
Tel.: +49 2558 81-0
Fax: +49 2558 81-500
E-Mail: info@cargobull.com
www.cargobull.com

Cargobull Trailer Center Hamburg
Liebigstraße 103
D-22113 Hamburg
Tel.: +49 40 529872-0
Fax: +49 40 529872-19
E-Mail: ctc.nord@cargobull.com
www.cargobull.com

Cargobull Trailer Center Neuss
Welser Str. 8
D-41468 Neuss-Uedesheim
Tel.: +49 2131 12559-00
Fax: +49 2131 12559-10
E-Mail: ctc.west@cargobull.com
www.cargobull.com

Cargobull Trailer Center Berlin
Robert-Guthmann-Str. 9
D-15713 Königs Wusterhausen
Tel.: +49 3375 5257979
Fax: +49 3375 5257980
E-Mail: ctc.ost@cargobull.com
www.cargobull.com

Cargobull Trailer Center Augsburg
Winterbrückenweg 27
D-86316 Friedberg-Derching
Tel.: +49 821 3434555
Fax: +49 821 3434550
E-Mail: ctc.sued@cargobull.com
www.cargobull.com

A Schmitz Austria Ges.m.b.H.

Bayernstrasse 54
A-5071 Wals-Siezenheim
Tel.: +43 662 8815870
Fax: +43 662 88158715
E-Mail: vertrieb@cargobull.at
www.cargobull.com/at

B Schmitz Cargobull Belgium BVBA

Skaldenstraat 121 A4 - Haven 3230
B-9042 Gent
Tel.: +32 9 3775188
Fax: +32 9 3777235
E-Mail: info.belgium@cargobull.com
www.cargobull.com

BG Schmitz Cargobull Bulgaria e.o.o.d.

Blvd. Botevgradsko
schosse Nr. 276
BG-1839 Sofia
Tel.: +359 2 8920555
Fax: +359 2 8411028
E-Mail: info@cargobull.bg
www.cargobull.com

BiH Schmitz Cargobull d.o.o.

Vlakovo br.10
BiH-71215 Blazuj (Sarajevo)
Tel.: +387 33 761520
Fax: +387 33 761521
E-Mail: Stanislav.Koleska@cargobull.ba
www.cargobull.com

BY Schmitz Cargobull AG

Repräsentanz Minsk
Fiskulturny Per. 1a
BY-220028 Minsk
Tel.: +375 17 2850969
Fax: +375 17 2851241
E-Mail: info.belorussia@cargobull.com
www.cargobull.com

CH Cargobull (Schweiz) AG

Rüttistaldenstr. 22
CH-4950 Huttwil
Tel.: +41 62 9595050
Fax: +41 62 9595060
E-Mail: info.chhuttwil@cargobull.com
www.cargobull.com

CZ EWT spol. s.r.o.

Zápy 255
CZ-25001 Brandýs nad Labem
Tel.: +420 326 901200
Fax: +420 326 901201
E-Mail: info@ewt.cz
www.ewt.cz

DK Schmitz Cargobull Danmark A/S

Europavej 1
DK-6330 Padborg
Tel.: +45 74 674024
Fax: +45 74 674077
E-Mail: Schmitz@schmitz.dk
www.cargobull.com/dk

E Schmitz Cargobull Ibérica, S.A.

Ctra. de Alagón – La Almunia A-122,
Km. 0,1 Polígono P7
E-50639 Figueruelas (Zaragoza)
Tel.: +34 976 613200
Fax: +34 976 613201
E-Mail: info.spain@cargobull.com
www.cargobull.com

EE Auto Trailer AS
 Taevavärava tee 9A
 EE-75306 Rae vald, Jüri
 Tel.: +372 6 064245
 Fax: +372 6 064247
 E-Mail: info@autotrailer.ee
 www.hansetrailer.com/ee

F Schmitz Cargobull France s.a.r.l.
 CTC Nancy
 Zone Industrielle des Sables
 Route des Sables
 F-54110 Dombasle sur Meurthe
 Tel.: +33 383 512205
 Fax: +33 383 513895
 E-Mail: info.nancy@cargobull.com
 www.cargobull.com/fr

F Schmitz Cargobull France s.a.r.l.
 CTC Paris
 5, rue de la Corderie. Centra 385
 F-94596 Rungis Cedex
 Tel.: +33 1 46870047
 Fax: +33 1 46872745
 E-Mail: info.paris@cargobull.com
 www.cargobull.com/fr

F Schmitz Cargobull France s.a.r.l.
 CTC Lyon
 Chemin du Lortaret
 F-69800 St. Priest
 Tel.: +33 472 794949
 Fax: +33 478 900086
 E-Mail: info.lyon@cargobull.com
 www.cargobull.com/fr

FIN Hanse Trailer Finland Oy
 Toinen Savu 8
 FIN-01510 Vantaa
 Tel.: +358 207 545890
 Fax: +358 207 545891
 E-Mail: info@hansetrailer.fi
 www.hansetrailer.com/fi

GB Schmitz Cargobull (UK) Ltd.
 North Road
 Harelaw, Stanley
 GB-Co. Durham DH9 8HJ
 Tel.: +44 1207 282882
 Fax: +44 1207 232479
 E-Mail: info.uk@cargobull.com
 www.cargobull.com/uk

GR Schmitz Cargobull S.E.E. A.E
 57o km N.E.O. Athinon-Korinthou
 GR-T.K. 19100 Kombos Kinetta
 Tel.: +30 22960 63799
 Fax: +30 22960 63769
 E-Mail: info@cargobull.gr
 www.cargobull.com

H Schmitz Cargobull Magyarország Kft.
 Szélescsapás 0321/4 hrsz.
 H-2060 Bicske
 Tel.: +36 22 814100
 Fax: +36 22 814111
 E-Mail: info.hungaria@cargobull.com
 www.cargobull.com/hu

HR Schmitz Cargobull d.o.o.
 Ljudevita Posavskog 29
 HR-10360 Sesvete (Zagreb)
 Tel.: +385 1 2013914
 Fax: +385 1 2013916
 E-Mail: schmitz@cargobull.hr
 www.cargobull.com

I Schmitz Cargobull Italia s.r.l.
 Via Cesarina, 23
 I-37066 Sommacampagna (VR)
 Tel.: +39 045 8961910
 Fax: +39 045 8960988
 E-Mail: info.italy@cargobull.com
 www.cargobull.com/it

- LT Hanse Trailer UAB**
Kirtimų g. 11A
LT-02300 Vilnius
Tel.: +370 5 2641520
Fax: +370 5 2641535
E-Mail: info@htl.lt
www.htl.lt
- LV Hanse Trailer Baltija SIA**
Lubānas iela 78
LV-1073 Rīga
Tel.: +371 6 7795255
Fax: +371 6 7795233
E-Mail: info@hansetrailer.lv
www.hansetrailer.lv
- MD I.C.S. Schmitz Cargobull S.R.L.**
str. Burebista 108, off. 213
MD-2032 Chisinau
Tel.: +373 2 2571163
Fax: +373 2 2571163
E-Mail: Vadim.Gurulea@cargobull.md
www.cargobull.com
- MK Schmitz Cargobull Makedonien dooel**
ul. 2 bb. naselba Ilinden
MK-1000 Skopje
Tel.: +389 2 581560
Fax: +389 2 572001
E-Mail: M.Simonovska-Cuka@cargobull.com.mk
www.cargobull.com

- NL Schmitz Trailer B.V.**
Campagneweg 34 A
NL-4761 RM Zevenbergen
Tel.: +31 168 331199
Fax: +31 168 331198
E-Mail: info.nl@cargobull.com
www.cargobull.com
- P Schmitz Cargobull Portugal Unipessoal Lda.**
Zona Industrial da Quinta do Sanguinhal
Apartado 173
P-2040-998 Rio Maior
Tel.: +351 243 999530
Fax: +351 243 999539
E-Mail: info.portugal@cargobull.com
www.cargobull.com/pt
- PL EWT Truck & Trailer Polska Sp.z.o.o.**
Ołtarzew ul. Poznańska 339
PL-05-850 Ożarów Mazowiecki
Tel.: +48 227 335300
Fax: +48 227 335302
E-Mail: ewt@ewt.pl
www.ewt.pl

- PL EWT Truck & Trailer Polska sp. z o.o.**
ul. Lubeckiego 1A
PL-71-656 Szczecin
Tel.: +48 22 7211140
Fax: +48 22 7224238
E-Mail: ewt@ewt.pl
www.ewt.pl
- RO Schmitz Cargobull Romania S.R.L.**
B-dul Timisoara nr. 92
RO-061334 Bukarest
Tel.: +40 21 4443555
Fax: +40 21 4443568
E-Mail: info@cargobull.ro
www.cargobull.com/ro
- RUS Schmitz Cargobull Russland OOO**
Nikulinskaya, dom 6, kosp. 3
RUS-119602 Moskau
Tel.: +7 495 6428259
Fax: +7 495 6428269
E-Mail: info@cargobull.ru
www.cargobull.com/ru

RUS Schmitz Cargobull Russland OOO

Niederlassung St. Petersburg
 ul. Koli Tomchaka 8 lit. A
 Office Nr. 218
 RUS-196084 St. Petersburg
 Tel.: +7 812 3884647
 Fax: +7 812 3883819
 E-Mail: spb@cargobull.ru
 www.cargobull.com/ru

S Schmitz Cargobull Sverige AB

Torbornavägen 22
 S-253 68 Helsingborg
 Tel.: +46 42 294960
 Fax: +46 42 296330
 E-Mail: info.schweden@cargobull.com
 www.cargobull.com

SK Central Europe Trailer s.r.o.

Diaľničná cesta 16
 SK-90301 Senec
 Tel.: +421 2 40209623
 Fax: +421 2 40209630
 E-Mail: cet@cet.sk
 www.cet.sk

SLO Schmitz Cargobull d.o.o.

Koroska cesta 51
 SLO-2366 Muta
 Tel.: +386 2 8761291
 Fax: +386 2 8761220
 E-Mail: bojan.miklavc@cargobull.si
 www.cargobull.com

SRB Schmitz Cargobull d.o.o.

Novi novosadski put bb
 SRB-11273 Batajnica, Beograd
 Tel.: +381 11 3774630
 Fax: +381 11 3774633
 E-Mail: Office@cargobull.rs
 www.cargobull.com

TR Enka Pazarlama Ihracat Ithalat A.S.

Istasyon Mah. Araplar cad. Nr. 6
 TR-34940 Tuzla-Istanbul
 Tel.: +90 216 4466464
 Fax: +90 216 4467286
 E-Mail: info@schmitztrailer.com
 www.cargobull.com

UA Schmitz Cargobull AG

Repräsentanz Kiew
 Prospekt Pobedy 89 A
 House No. 2, Office 10
 UA-03115 Kiew
 Tel.: +380 44 4902291
 Fax: +380 44 4902283
 E-Mail: info.ukraine@cargobull.com
 www.cargobull.com

Overseas

Africa · Central Asia

Near East/Middle East/Far East

TRAILER ENGINEERING

Niederhauser & Co.

Baarerstraße 96

CH-6302 Zug

Tel.: +41 41 7691900

Fax: +41 41 7691901

E-Mail: info@schmitztrailer.com

www.schmitztrailer.com

Australien/Neuseeland

Schmitz Cargobull PTY LTD

PO Box 65

Miranda NSW 1490

Sydney · Australia

E-Mail: trailers@schmitzcargobull.com.au

E-Mail: info@schmitztrailer.com

www.schmitzcargobull.com.au



Regarding the information in this catalogue: Product changes may occur after the editorial deadline for this publication on april 2010. Design and shape changes as well as changes to the scope of delivery on the part of the manufacturer remain reserved for the entire period of delivery as long as the changes or deviations are reasonable for the purchaser, taking into account the interests of the vendors. If the vendor or the manufacturer utilise characters or numbers to identify the order or the object of purchase ordered then no rights can be derived from these alone. The illustrations and texts can also contain accessories and special fittings which are not included in the standard scope of delivery. The printing process may result in colour deviations. This publication may also contain types and support services which are not offered in individual countries. This catalogue is utilised internationally. However, statements regarding regulations, laws and tax regulations and effects only apply to the Federal Republic of Germany at the time of the editorial deadline for this catalogue. As such, please contact your Schmitz Cargobull contact should you have any questions concerning the applicable regulations and their effects and the current version of these regulations and their effects in your country.

ROTOS®, TrailerConnect®, Cargobull Euroservice®, S.KI, M.KI, Z.KI, S.SF, A.CF, S.CS, M.CS, Z.CS, S.PR, S.KO, M.KO, Z.KO, S.CF, Z.CF, Z.WF are registered trademarks of Schmitz Cargobull AG.

**SCHMITZ
CARGOBULL** 
The Trailer Company.



just more.